

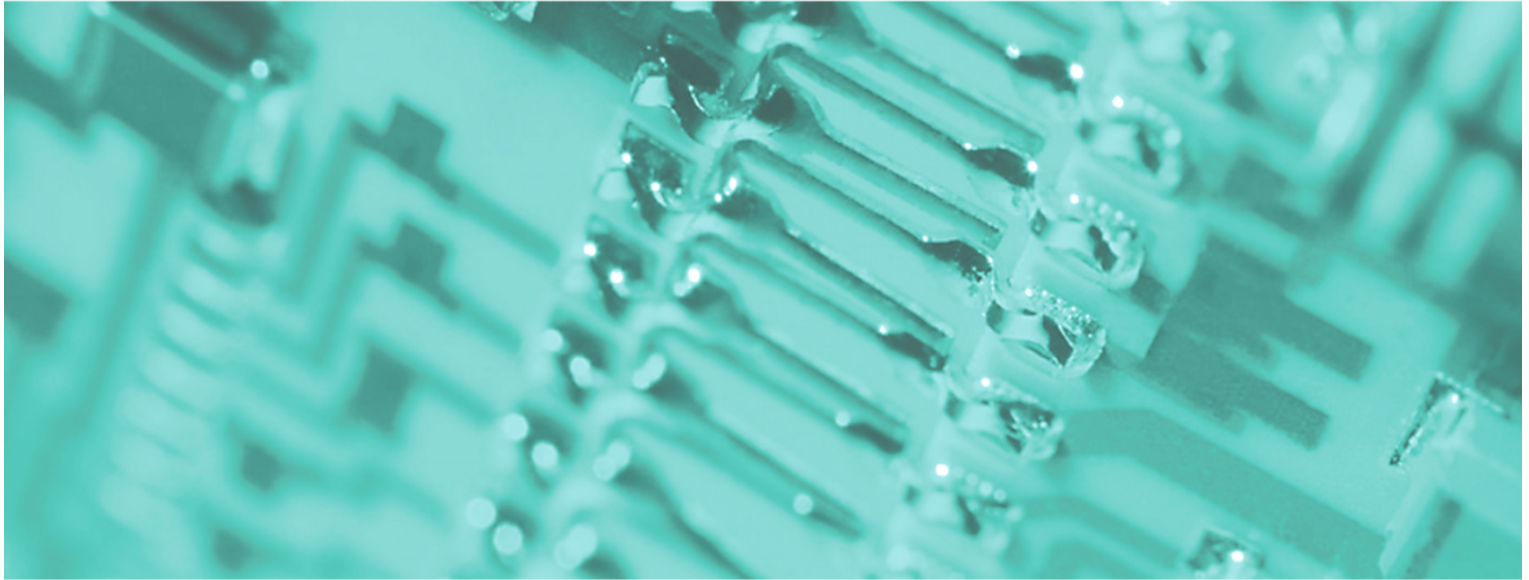

VIPA System 300V



PS | Manual

HB130E_PS | Rev. 09/46

November 2009

Copyright © VIPA GmbH. All Rights Reserved.

This document contains proprietary information of VIPA and is not to be disclosed or used except in accordance with applicable agreements.

This material is protected by the copyright laws. It may not be reproduced, distributed, or altered in any fashion by any entity (either internal or external to VIPA), except in accordance with applicable agreements, contracts or licensing, without the express written consent of VIPA and the business management owner of the material.

For permission to reproduce or distribute, please contact:
VIPA, Gesellschaft für Visualisierung und Prozessautomatisierung mbH
Ohmstraße 4, D-91074 Herzogenaurach, Germany
Tel.: +49 (91 32) 744 -0
Fax.: +49 9132 744 1864
EMail: info@vipa.de
<http://www.vipa.de>

Note

Every effort has been made to ensure that the information contained in this document was complete and accurate at the time of publishing. Nevertheless, the authors retain the right to modify the information. This customer document describes all the hardware units and functions known at the present time. Descriptions may be included for units which are not present at the customer site. The exact scope of delivery is described in the respective purchase contract.

CE Conformity

Hereby, VIPA GmbH declares that the products and systems are in compliance with the essential requirements and other relevant provisions of the following directives:

- 2004/108/EC Electromagnetic Compatibility Directive
- 2006/95/EC Low Voltage Directive

Conformity is indicated by the CE marking affixed to the product.

Conformity Information

For more information regarding CE marking and Declaration of Conformity (DoC), please contact your local VIPA customer service organization.

Trademarks

VIPA, SLIO, System 100V, System 200V, System 300V, System 300S, System 400V, System 500S and Commander Compact are registered trademarks of VIPA Gesellschaft für Visualisierung und Prozessautomatisierung mbH.

SPEED7 is a registered trademark of profichip GmbH.

SIMATIC, STEP, SINEC, S7-300 and S7-400 are registered trademarks of Siemens AG.

Microsoft und Windows are registered trademarks of Microsoft Inc., USA.

Portable Document Format (PDF) and Postscript are registered trademarks of Adobe Systems, Inc.

All other trademarks, logos and service or product marks specified herein are owned by their respective companies.

Information product support

Contact your local VIPA Customer Service Organization representative if you wish to report errors or questions regarding the contents of this document. If you are unable to locate a customer service center, contact VIPA as follows:

VIPA GmbH, Ohmstraße 4, 91074 Herzogenaurach, Germany

Telefax: +49 9132 744 1204
EMail: documentation@vipa.de

Technical support

Contact your local VIPA Customer Service Organization representative if you encounter problems with the product or have questions regarding the product. If you are unable to locate a customer service center, contact VIPA as follows:

VIPA GmbH, Ohmstraße 4, 91074 Herzogenaurach, Germany

Telephone: +49 9132 744 1150/1180 (Hotline)
EMail: support@vipa.de

Contents

About this manual	1
Safety information	2
Chapter 1 Basics	1-1
Safety Information for Users.....	1-2
General description of the System 300V	1-3
Components.....	1-4
Chapter 2 Assembly and installation guidelines.....	2-1
Overview	2-2
Installation dimensions	2-3
Installation at the profile rail.....	2-4
Cabling	2-6
Installation Guidelines	2-10
Chapter 3 PS 307 power supply	3-1
Safety Information	3-2
System overview	3-3
307-1BA00 - Deployment	3-4
307-1BA00 - Technical data.....	3-6
307-1EA00 - Deployment	3-7
307-1EA00 - Technical data	3-10
307-1KA00 - Deployment	3-11
307-1KA00 - Technical data	3-14
Appendix	A-1
Index	A-1

About this Manual

This manual describes the System 300V power supplies (PS) from VIPA. In addition to the product summary it contains detailed descriptions of the different modules. You are provided with information on the connection and the utilization of the PS 307 power supplies in the System 300.

Overview

Chapter 1: Introduction



This introduction includes recommendations on the handling of the modules of the VIPA System 300V and introduces you to central res. decentral automation systems.

Chapter 2: Installation and assembly guide lines

All information that you need for installation and cabling of a PLC with components of the System 300V.

Chapter 3: PS 307 power supply

This chapter contains a description of the System 300V power supplies. Here you find a comprehensive set of safety related hints and information as well as details on the construction, the installation and commissioning of the modules.

Objective and contents	This manual describes power supplies (PS) which can be used with the System 300V. It contains a description of structure, deployment and technical data.
Target audience	The manual is targeted at users who have a background in automation technology.
Structure of the manual	The manual consists of chapters. Every chapter provides a self-contained description of a specific topic.
Guide to the document	The following guides are available in the manual: <ul style="list-style-type: none">• an overall table of contents at the beginning of the manual• an overview of the topics for every chapter• an index at the end of the manual.
Availability	The manual is available in: <ul style="list-style-type: none">• printed form, on paper• in electronic form as PDF-file (Adobe Acrobat Reader)
Icons Headings	Important passages in the text are highlighted by following icons and headings:
	Danger! Immediate or likely danger. Personal injury is possible.
	Attention! Damages to property is likely if these warnings are not heeded.
	Note! Supplementary information and useful tips.

Safety information

Applications conforming with specifications

The modules of the System 300V are constructed and manufactured for:

- System 300 components of VIPA and Siemens
- communication and process control
- general control and automation applications
- industrial applications
- operation within the environmental conditions specified in the technical data
- installation into a cubicle



Danger!

This device is not certified for applications in

- in explosive environments (EX-zone)

Documentation

The manual must be available to all personnel in the

- project design department
- installation department
- commissioning
- operation



The following conditions must be met before using or commissioning the components described in this manual:

- Modification to the process control system should only be carried out when the system has been disconnected from power!
- Installation and modifications only by properly trained personnel
- The national rules and regulations of the respective country must be satisfied (installation, safety, EMC ...)

Disposal

National rules and regulations apply to the disposal of the unit!

Chapter 1 Basics

Outline

Main theme of this chapter is to give you an overview about the System 300V from VIPA. We will outline the possibilities of the installation of central res. decentral systems.

This chapter also contains general information about the System 300V like measurements, hints for installation and the environmental conditions.

Content

Topic	Page
Chapter 1 Basics	1-1
Safety Information for Users.....	1-2
General description of the System 300V	1-3
Components.....	1-4

Safety Information for Users

Handling of electrostatically sensitive modules

VIPA modules make use of highly integrated components in MOS-Technology. These components are extremely sensitive to over-voltages that can occur during electrostatic discharges.

The following symbol is attached to modules that can be destroyed by electrostatic discharges.



The symbol is located on the module, the module rack or on packing material and it indicates the presence of electrostatically sensitive equipment.

It is possible that electrostatically sensitive equipment is destroyed by energies and voltages that are far less than the human threshold of perception. These voltages can occur where persons do not discharge themselves before handling electrostatically sensitive modules and they can damage components thereby, causing the module to become inoperable or unusable. Modules, damaged in this way, are normally not immediately recognized. The according error may occur only after a while of operation.

Modules that have been damaged by electrostatic discharges can fail after a temperature change, mechanical shock or changes in the electrical load.

Only the consequent implementation of protection devices and meticulous attention to the applicable rules and regulations for handling the respective equipment can prevent failures of electrostatically sensitive modules.

Shipping of modules

Modules must be shipped in the original packing material.

Measurements and alterations on electrostatically sensitive modules

When you are conducting measurements on electrostatically sensitive modules you should take the following precautions:

- Floating instruments must be discharged before use.
- Instruments must be grounded.

Modifying electrostatically sensitive modules you should only use soldering irons with grounded tips.



Attention!

Personnel and instruments should be grounded when working on electrostatically sensitive modules.

General description of the System 300V

The System 300V

The System 300V is a modular automation system for middle and high performance needs, that you can use either distributed or non-distributed. The single modules are directly clipped to a 530 mm backplane and are connected together with the help of bus clips at the backside.

The single modules of the VIPA System 300V are design compatible to Siemens. Due to the compatible backplane bus it is no problem to mix the modules from VIPA and Siemens.

The CPUs of the System 300V are instruction set compatible to S7-300 from Siemens. The CPUs are programmed via the VIPA programming software WinPLC7 or the SIMATIC manager from Siemens or other available programming tools.

The following picture illustrates the performance range of the System 300V:

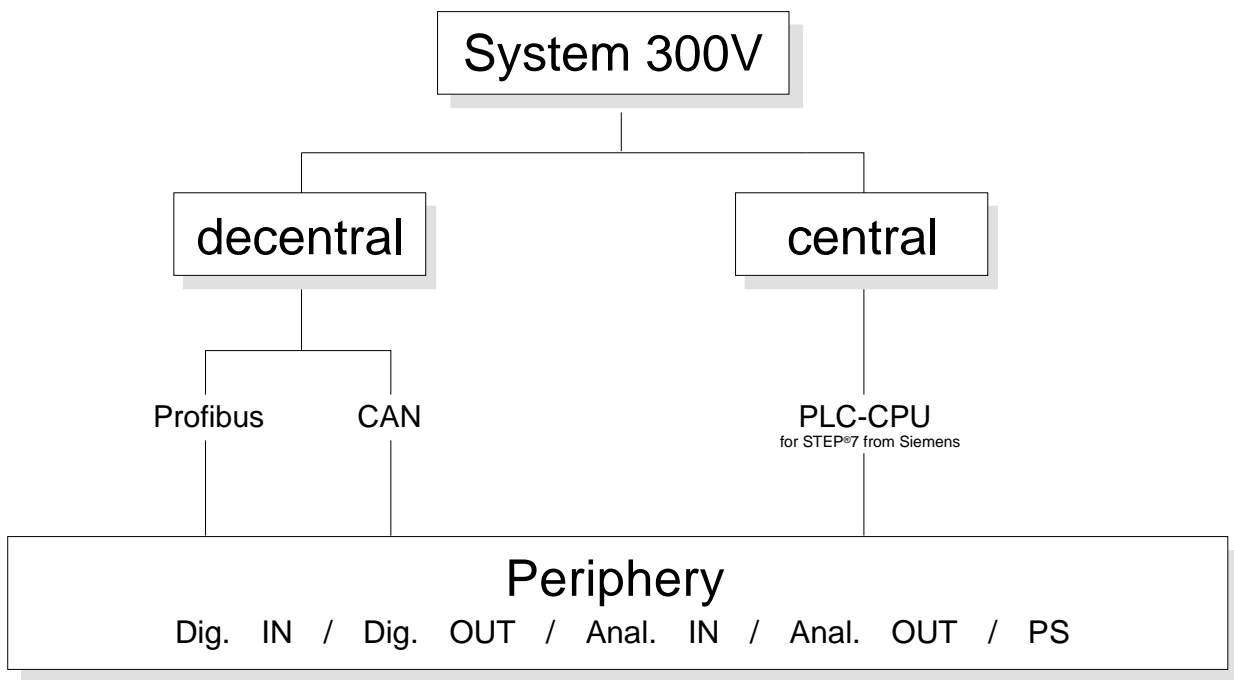

Components

Central system

The System 200V series consists of a number of PLC-CPU's. These are programmed in STEP[®]7 from Siemens. Herefore you may use WinPLC7 from VIPA or the SIMATIC manager from Siemens.

CPU's with integrated Ethernet interfaces or additional serial interfaces simplify the integration of the PLC into an existing network or the connection of additional peripheral equipment.

The application program is saved in Flash or an additional plug-in memory module.

Because of the automatic addressing, up to 32 peripheral modules can be called by the System 300V CPU's.

Decentral system

In combination with a Profibus DP master and slave the PLC-CPU's or the PC-CPU form the basis for a Profibus-DP network in accordance with DIN 19245-3.

The DP network can be configured with the hardware configurator from Siemens. Together with the hardware configuration you transfer your project into the CPU via MPI. Another component of the decentral system is the CAN-Slave. It allows the link-up to the fieldbus system CANopen.

Peripheral modules

A large number of peripheral modules are available from VIPA, for example digital as well as analog inputs/outputs.

These peripheral modules can be deployed central as well as decentral.

Dimensions/Weight

- Profile rail 530mm
- Peripheral modules with recessed labeling
- Dimensions of the basic enclosure:
 - 1tier width: (WxHxD) in mm: 40x125x120
 - 2tier width: (WxHxD) in mm: 80x125x120
 - 3tier width: (WxHxD) in mm: 120x125x120

Installation

Please regard that the power supply and header modules like CPU's and couplers may only plugged-in at the left side.

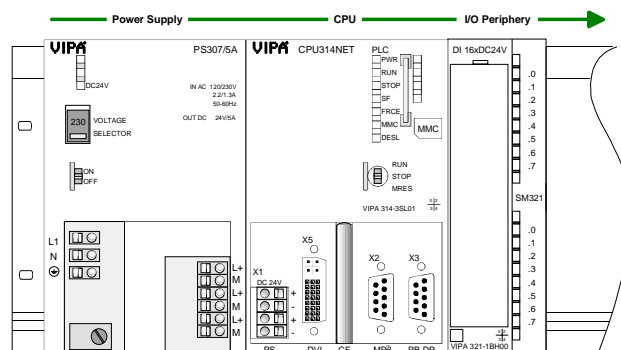

- Reliability**
- Wiring by means of spring pressure connections (CageClamps) at the front connector
 - Core cross-section 0.08...2.5mm² or 1.5 mm²
 - Total isolation of the wiring at module change
 - Potential separation of all modules to the backplane bus
 - Burst/ESD acc. IEC 61000-4-2/IEC 61000-4-4 (up to level 3)
 - Shock resistance acc. IEC 60068-2-6 / IEC 60068-2-27 (1G/12G)

- Environmental conditions**
- Operating temperature: 0 ... +60°C
 - Storage temperature: -25 ... +70°C
 - Relative humidity: 5...95% without condensation
 - Ventilation by means of a fan is not required

Green Cable for project engineering

For project engineering of your DP slave you may transfer your projects from your PC to the CPU serial via MPI by using the "Green Cable". Please also regard the hints to the Green Cable in this chapter!

Integrated power supply

Every Profibus slave has an internal power supply. This power supply requires DC 24V. In addition to the electronics on the bus coupler, the supply voltage is also used to power any modules connected to the backplane bus. Please note that the maximum current that the integrated power supply can deliver to the backplane bus is 3.5A.

The power supply is protected against reverse polarity and overcurrent.

Compatibility

The digital in-/output modules of the System 300V from VIPA are pin and function compatible to Siemens.

The project engineering happens in the SIMATIC manager from Siemens.



Note!

For programming of a System 300V CPU from VIPA please use always the **CPU 315-2DP (6ES7 315-2AF03 V1.2)** from Siemens in the hardware catalog.

Please note the Profibus address 1 of the CPU 31x is system dependent reserved.

For the project engineering, a thorough knowledge of the Siemens SIMATIC manager and the hardware configurator is required!

Chapter 2 Assembly and installation guidelines

Outline In this chapter you will find all information, required for the installation and the cabling of a process control with the components of the System 300V.

Content	Topic	Page
	Chapter 2 Assembly and installation guidelines.....	2-1
	Overview	2-2
	Installation dimensions	2-3
	Installation at the profile rail.....	2-4
	Cabling.....	2-6
	Installation Guidelines	2-10

Overview

General

The single modules are directly installed on a profile rail and connected via the backplane bus coupler. Before installing the modules you have to clip the backplane bus coupler to the module from the backside. The backplane bus coupler are included in the delivery of the peripheral modules.

Profile rail

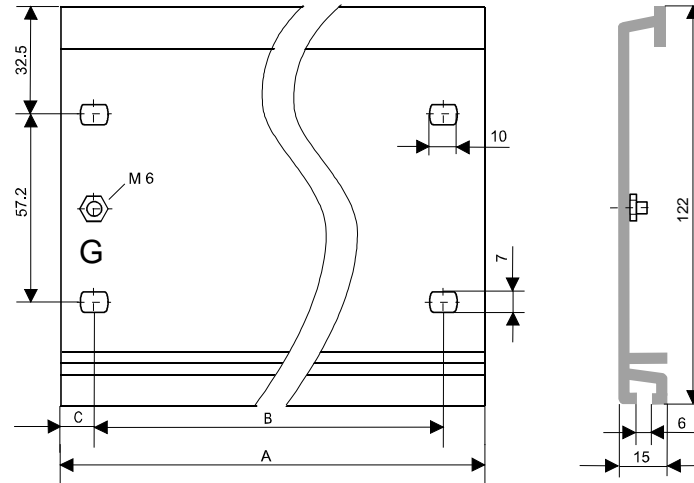

Order number	A	B	C
VIPA 390-1AB60	160mm	140mm	10mm
VIPA 390-1AE80	482mm	466mm	8.3mm
VIPA 390-1AF30	530mm	500mm	15mm
VIPA 390-1AJ30	830mm	800mm	15mm
VIPA 390-9BC00*	2000mm	no Drillings	15mm

* Unit pack: 10 pieces

Bus connector

For the communication between the modules the System 300V uses a backplane bus connector. The backplane bus connector are included in the delivering of the peripheral modules and are clipped at the module from behind before installing it to the profile rail.

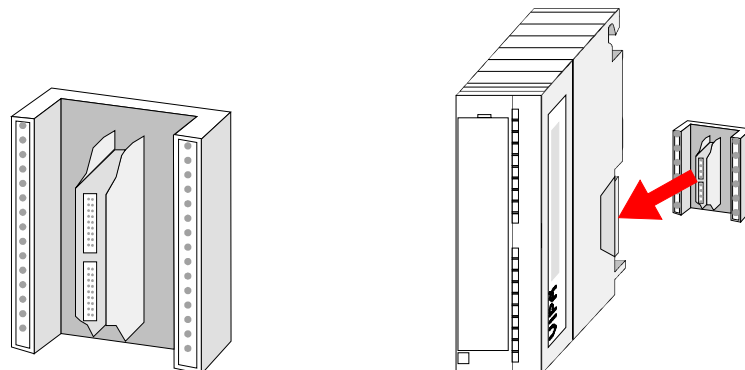

Installation dimensions

Overview

Here follows all the important dimensions of the System 300V.

Dimensions Basic enclosure

1tier width (WxHxD) in mm: 40 x 125 x 120

2tier width (WxHxD) in mm: 80 x 125 x 120

3tier width (WxHxD) in mm: 120 x 125 x 120

Dimensions

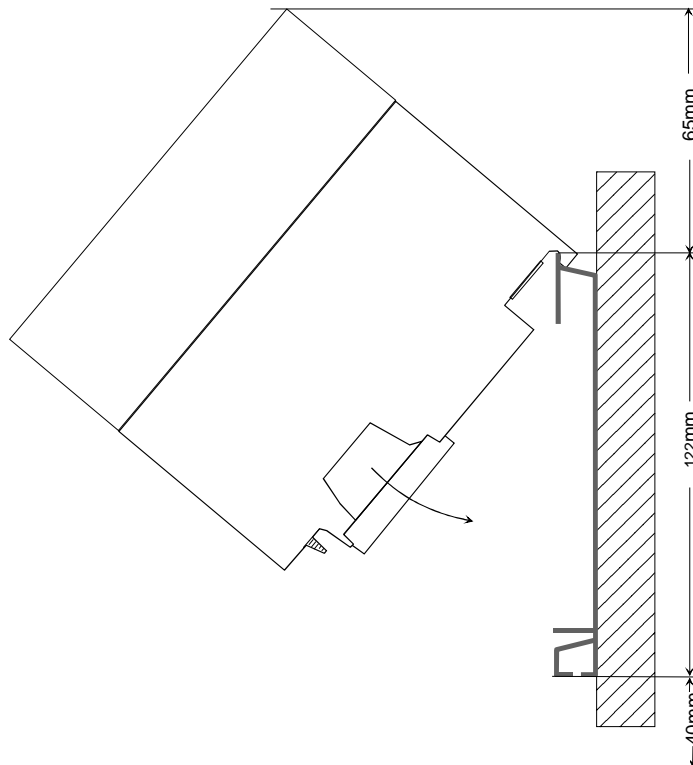

Installation dimensions

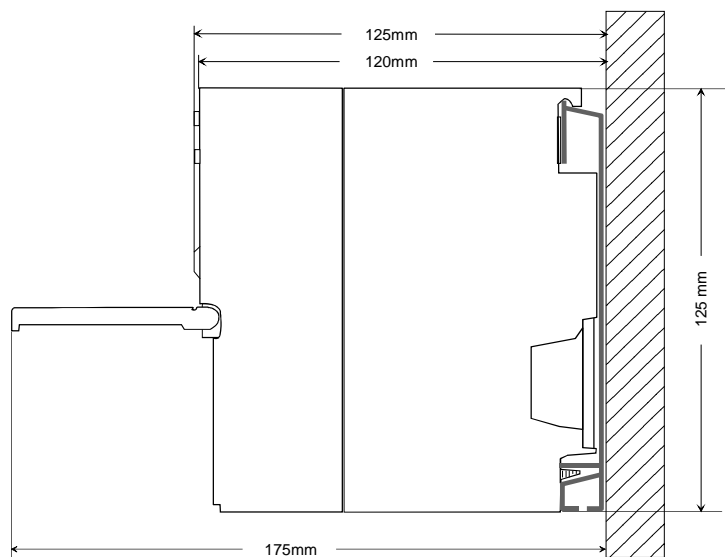

Installation at the profile rail

Structure:

You may install the System 300V as well horizontal as vertical. Please regard the allowed environment temperatures:

- horizontal structure: from 0 to 60°
- vertical structure: from 0 to 40°

The horizontal structure always starts at the left side with the power supply and the CPU, then you plug-in the peripheral modules beside to the right. You may plug-in maximum 32 peripheral modules to the CPU.

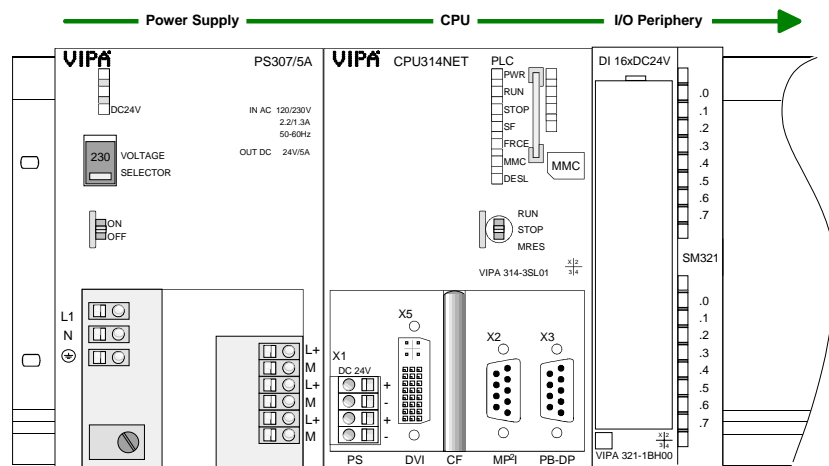

The vertical structure is turned for 90° against the clockwise direction.

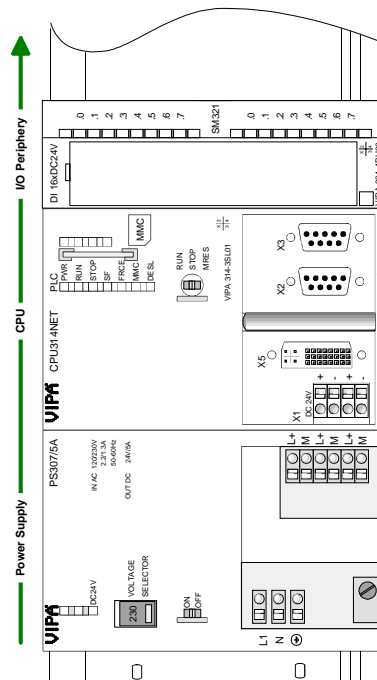

Approach

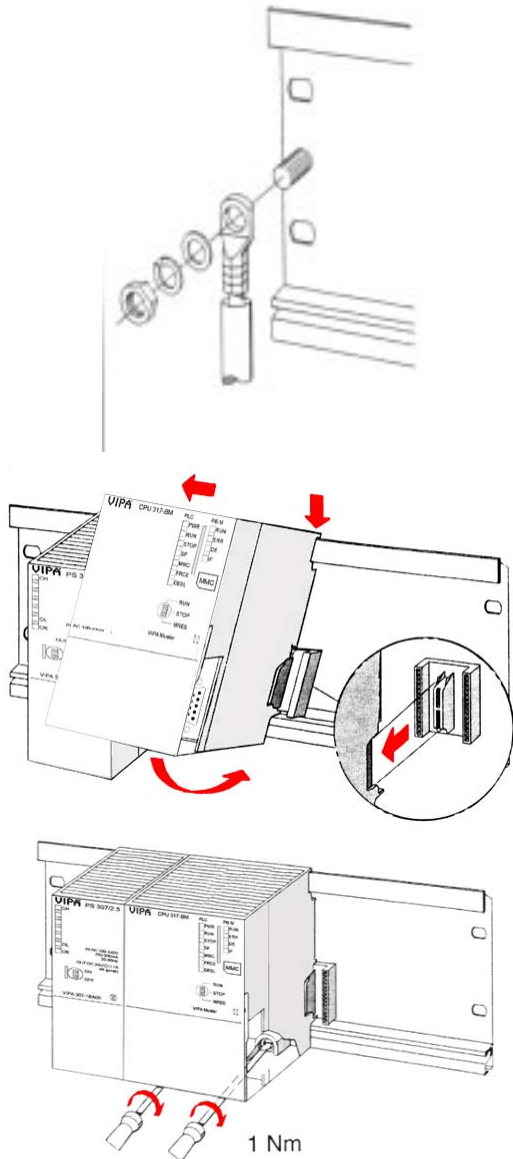

- Bolt the profile rail with the background (screw size: M6), so that you still have minimum 65mm space above and 40mm below the profile rail.
- If the background is a grounded metal or device plate, please look for a low-impedance connection between profile rail and background.
- Connect the profile rail with the protected earth conductor. For this purpose there is a bolt with M6-thread.
- The minimum cross-section of the cable to the protected earth conductor has to be 10mm².
- Stick the power supply to the profile rail and pull it to the left side to the grounding bolt of the profile rail.
- Fix the power supply by screwing.
- Take a bus coupler and click it at the CPU from behind like shown in the picture.
- Stick the CPU to the profile rail right from the power supply and pull it to the power supply.
- Click the CPU downwards and bolt it like shown.
- Repeat this procedure with the peripheral modules, by clicking a backplane bus coupler, stick the module right from the modules you've already fixed, click it downwards and connect it with the backplane bus coupler of the last module and bolt it.



Danger!

- Before installing or overhauling the System 300V, the power supplies must be disconnected from voltage (pull the plug or remove the fuse)!
- Installation and modifications only by properly trained personnel!

Cabling

Overview

The power supplies and CPUs are exclusively delivered with CageClamp contacts. For the signal modules the front connectors are available from VIPA with screw contacts. In the following all connecting types of the power supplies, CPUs and input/output modules are described.



Danger!

- Before installation or overhauling, the power supplies must be disconnected from voltage (pull the plug or remove the fuse)!
- Installation and modifications only by properly trained personnel!

CageClamp technology (gray)

For the cabling of power supplies, bus couplers and parts of the CPU, gray connectors with CageClamp technology are used.

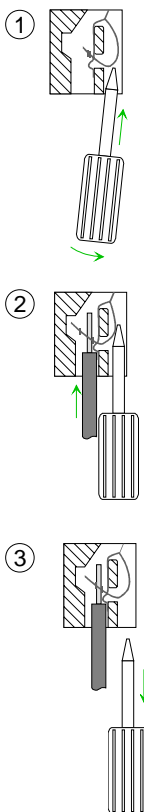

You may connect wires with a cross-section of 0.08mm² to 2.5mm². You can use flexible wires without end case as well as stiff wires.

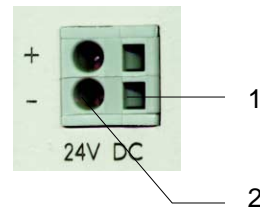

- [1] Rectangular opening for screwdriver
- [2] Round opening for wires

The picture on the left side shows the cabling step by step from top view.

- To conduct a wire you plug a fitting screwdriver obliquely into the rectangular opening like shown in the picture.
- To open the contact spring you have to push the screwdriver in the opposite direction and hold it.
- Insert the insulation striped wire into the round opening. You may use wires with a cross-section from 0.08mm² to 2.5mm².
- By removing the screwdriver the wire is connected safely with the plug connector via a spring.

CageClamp technology (green)

For the cabling of e.g. the power supply of a CPU, green plugs with CageClamp technology are deployed.

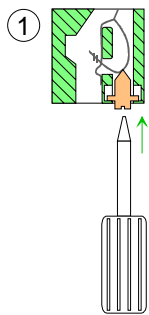

Here also you may connect wires with a cross-section of 0.08mm^2 to 2.5mm^2 . You can use flexible wires without end case as well as stiff wires.

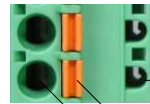

- [1] Test point for 2mm test tip
- [2] Locking (orange) for screwdriver
- [3] Round opening for wires

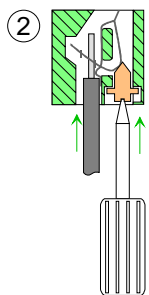

The picture on the left side shows the cabling step by step from top view.

- For cabling you push the locking vertical to the inside with a suiting screwdriver and hold the screwdriver in this position.
- Insert the insulation striped wire into the round opening. You may use wires with a cross-section from 0.08mm^2 to 2.5mm^2 .
- By removing the screwdriver the wire is connected safely with the plug connector via a spring.

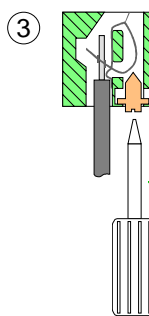

**Note!**

In opposite to the gray connection clamp from above, the green connection clamp is realized as plug that can be clipped off carefully even if it is still cabled.

Front connectors of the in-/output modules

In the following the cabling of the three variants of the front-facing connector is shown:

For the I/O modules the following plugs are available at VIPA:

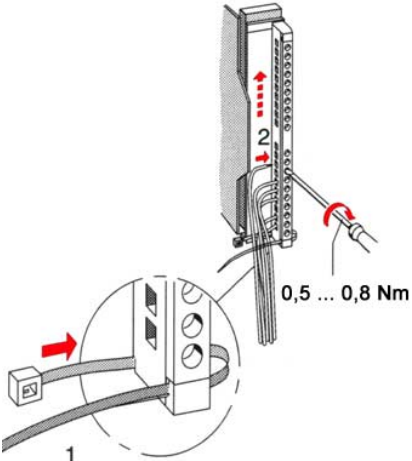
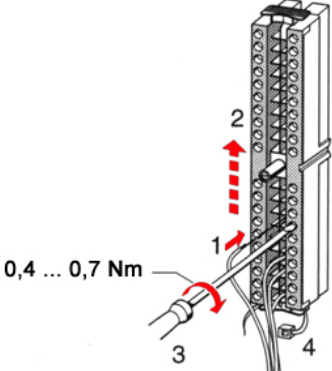
<p>20pole screw connection VIPA 392-1AJ00</p>	<p>40pole screw connection VIPA 392-1AM00</p>
	
<p>Open the front flap of your I/O module.</p>	
<p>Bring the front connector in cabling position. Herefore you plug the front connector on the module until it locks. In this position the front connector juts out of the module and has no contact yet.</p>	
<p>Deisolate your wires. If needed, use core end cases.</p>	
<p>Thread the included cable binder into the front connector.</p>	
<p>If you want to lead out your cables from the bottom of the module, start with the cabling from bottom to top, res. from top to bottom, if the cables should be led out at the top.</p>	
<p>Bolt also the connection screws of not cabled screw clamps.</p>	
	<p>Put the included cable binder around the cable bundle and the front connector.</p> 
<p>Fix the cable binder for the cable bundle.</p>	

continued ...

... continue

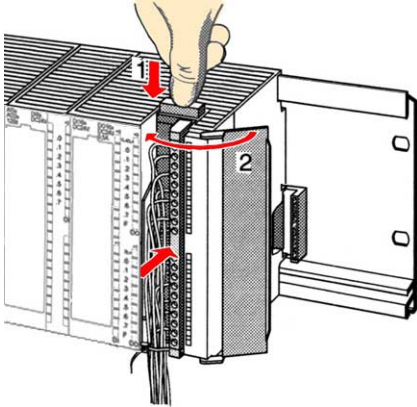
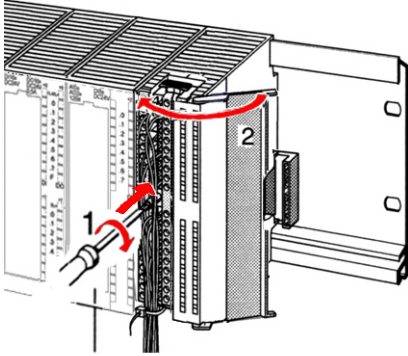
20pole screw connection	40pole screw connection
<p data-bbox="159 331 770 465">Push the release key at the front connector on the upper side of the module and at the same time push the front connector into the module until it locks.</p>  <p>The diagram shows a hand pressing a release key (1) on the top of a 20-pole connector. Red arrows indicate the key being pushed down and the connector being pushed into the module (2). The connector is shown with 20 pins.</p>	<p data-bbox="809 331 1366 365">Bolt the fixing screw of the front connector.</p>  <p>The diagram shows a screw being tightened (1) on the top of a 40-pole connector. Red arrows indicate the screw being turned clockwise and the connector being pushed into the module (2). The connector is shown with 40 pins.</p> <p data-bbox="932 891 1114 925">0.4 ... 0.7 Nm</p>
<p data-bbox="159 1003 1034 1037">Now the front connector is electrically connected with your module.</p>	
<p data-bbox="159 1070 416 1104">Close the front flap.</p>	
<p data-bbox="159 1137 1321 1171">Fill out the labeling strip to mark the single channels and push the strip into the front flap.</p>	

Installation Guidelines

General The installation guidelines contain information about the interference free deployment of System 300V systems. There is the description of the ways, interference may occur in your control, how you can make sure the electromagnetic digestibility (EMC), and how you manage the isolation.

What means EMC? Electromagnetic digestibility (EMC) means the ability of an electrical device, to function error free in an electromagnetic environment without being interferenced res. without interfering the environment.
All System 300V components are developed for the deployment in hard industrial environments and fulfill high demands on the EMC. Nevertheless you should project an EMC planning before installing the components and take conceivable interference causes into account.

Possible interference causes Electromagnetic interferences may interfere your control via different ways:

- Fields
- I/O signal conductors
- Bus system
- Current supply
- Protected earth conductor

Depending on the spreading medium (lead bound or lead free) and the distance to the interference cause, interferences to your control occur by means of different coupling mechanisms.

One differs:

- galvanic coupling
- capacitive coupling
- inductive coupling
- radiant coupling

Basic rules for EMC

In the most times it is enough to take care of some elementary rules to guarantee the EMC. Please regard the following basic rules when installing your PLC.

- Take care of a correct area-wide grounding of the inactive metal parts when installing your components.
 - Install a central connection between the ground and the protected earth conductor system.
 - Connect all inactive metal extensive and impedance-low.
 - Please try not to use aluminum parts. Aluminum is easily oxidizing and is therefore less suitable for grounding.
- When cabling, take care of the correct line routing.
 - Organize your cabling in line groups (high voltage, current supply, signal and data lines).
 - Always lay your high voltage lines and signal res. data lines in separate channels or bundles.
 - Route the signal and data lines as near as possible beside ground areas (e.g. suspension bars, metal rails, tin cabinet).
- Proof the correct fixing of the lead isolation.
 - Data lines must be laid isolated.
 - Analog lines must be laid isolated. When transmitting signals with small amplitudes the one sided laying of the isolation may be favorable.
 - Lay the line isolation extensively on a isolation/protected earth conductor rail directly after the cabinet entry and fix the isolation with cable clamps.
 - Make sure that the isolation/protected earth conductor rail is connected impedance-low with the cabinet.
 - Use metallic or metallized plug cases for isolated data lines.
- In special use cases you should appoint special EMC actions.
 - Wire all inductivities with erase links, that are not addressed by the System 300V modules.
 - For lightening cabinets you should prefer incandescent lamps and avoid luminescent lamps.
- Create an homogeneous reference potential and ground all electrical operating supplies when possible.
 - Please take care for the targeted employment of the grounding actions. The grounding of the PLC is a protection and functionality activity.
 - Connect installation parts and cabinets with the System 300V in star topology with the isolation/protected earth conductor system. So you avoid ground loops.
 - If potential differences between installation parts and cabinets occur, lay sufficiently dimensioned potential compensation lines.

Isolation of conductors

Electrical, magnetical and electromagnetical interference fields are weakened by means of an isolation, one talks of absorption.

Via the isolation rail, that is connected conductive with the rack, interference currents are shunt via cable isolation to the ground. Hereby you have to make sure, that the connection to the protected earth conductor is impedance-low, because otherwise the interference currents may appear as interference cause.

When isolating cables you have to regard the following:

- If possible, use only cables with isolation tangle.
- The hiding power of the isolation should be higher than 80%.
- Normally you should always lay the isolation of cables on both sides. Only by means of the both-sided connection of the isolation you achieve a high quality interference suppression in the higher frequency area.
Only as exception you may also lay the isolation one-sided. Then you only achieve the absorption of the lower frequencies. A one-sided isolation connection may be convenient, if:
 - the conduction of a potential compensating line is not possible
 - analog signals (some mV res. μA) are transferred
 - foil isolations (static isolations) are used.
- With data lines always use metallic or metallized plugs for serial couplings. Fix the isolation of the data line at the plug rack. Do not lay the isolation on the PIN 1 of the plug bar!
- At stationary operation it is convenient to deisolate the isolated cable interruption free and lay it on the isolation/protected earth conductor line.
- To fix the isolation tangles use cable clamps out of metal. The clamps must clasp the isolation extensively and have well contact.
- Lay the isolation on an isolation rail directly after the entry of the cable in the cabinet. Lead the isolation further on to the System 300V module and **don't** lay it on there again!

**Please regard at installation!**

At potential differences between the grounding points, there may be a compensation current via the isolation connected at both sides.

Remedy: Potential compensation line

Chapter 3 PS 307 power supply

Overview This chapter describes the power supply for the System 300V.

Content	Topic	Page
	Chapter 3 PS 307 power supply	3-1
	Safety Information	3-2
	System overview	3-3
	307-1BA00 - Deployment	3-4
	307-1BA00 - Technical data	3-6
	307-1EA00 - Deployment	3-7
	307-1EA00 - Technical data	3-10
	307-1KA00 - Deployment	3-11
	307-1KA00 - Technical data	3-14

Safety Information

- Application fields** The power supplies are constructed and manufactured for:
- DC 24V supply of System 300 components.
 - Installation together with other System 300 components on one panel.
 - Installation in a cubicle with air condition.
 - industrial usage.

- Assembly** Using the power supply:
- Install the power supply together with your System 300 modules on a profile rail. In this case the power supply has to be plugged on the outermost rim of your System 300, because otherwise the backplane bus is interrupted.
The power supplies are not connected to the backplane bus.

When selecting the installation position please take care that the power supply is cooled sufficiently during operation.

In the following you will find the precautions you should take into account by using the System 300V power supplies.



Danger!

- The power supplies may only be installed in dry environment where it can only be accessed by trained personnel!
- The power supplies are not certified for explosive environments (EX-Zone)!
- Before installing or overhauling the System 300V, the power supplies must be disconnected from voltage (pull the plug or remove the fuse)!
- Installation and modifications only by properly trained personnel!
- Due to the compact design, the contact and fire protection to guarantee sufficient cooling can not be obeyed. For this reason the fire protection has to be guaranteed by the construction of the environment of the power supply (e.g. installation in a cubicle that obeys the fire protection rules)!
- The national rules and regulations of the respective country must be satisfied (installation, safety, EMC ...)

System overview

Power supplies

The System 300V power supplies presented here have an adjustable input voltage of AC 120/230V and an output voltage of DC 24V. Depending upon the module the adjustment to the input voltage takes place automatically steplessly from AC 100....240V or by means of an AC 120/230V mains voltage selector switch.

For all the inputs and outputs are on the frontside and the module case is isolated to the backplane bus, you may install the power supply together with your System 300 modules on a profile rail.

The following power supplies are available from VIPA:

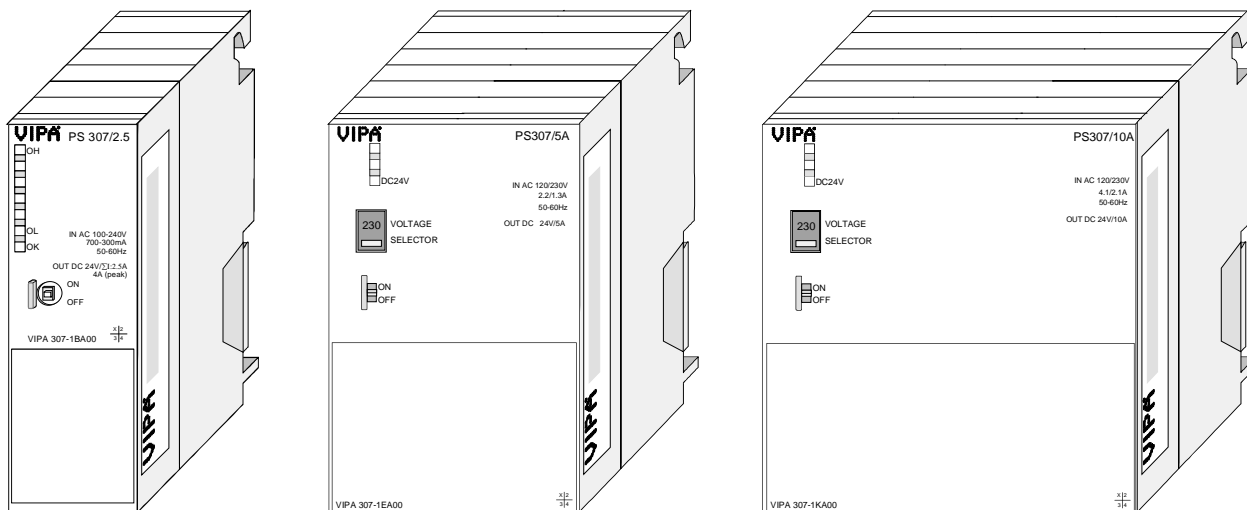

Order data

Order number	Description
VIPA 307-1BA00	Power supply Primary AC 100...240V, secondary DC 24V, 2.5A
VIPA 307-1EA00	Power supply Primary AC 120/230V, secondary DC 24V, 5A
VIPA 307-1KA00	Power supply Primary AC 120/230V, secondary DC 24V, 10A

307-1BA00 - Deployment

Order data PS 307/2.5A VIPA 307-1BA00

Properties

- Output current 2.5A
- Output voltage DC 24V
- Connection to single-phase AC mains
Wide-range input AC 100...240V without manual switch
- Protection against short circuits, overloads and vacancy
- Useable together with System 300 on profile rail
- Safety isolation to EN 60950
- Protection against overheat
- Efficiency typ. 90% at I_{nom}
- May be used as load power supply

Structure

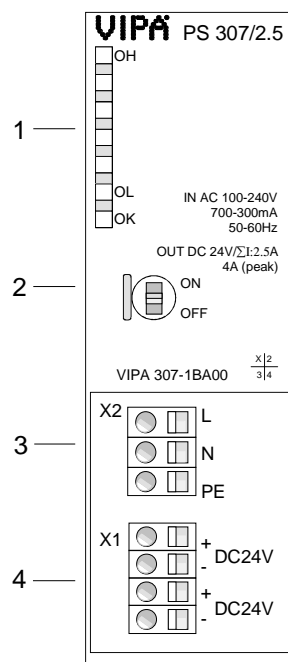

- [1] Status LED
[2] ON/OFF switch

The following components are beneath a flap:

- [3] AC IN 100 ... 240V
[4] DC OUT 24V, 2.5A



Danger!

- Before installing or overhauling single components res. the whole system, the power supplies must be disconnected from voltage (pull the plug or remove the fuse)!
- Installation and modifications only by properly trained personnel!

Circuit diagram

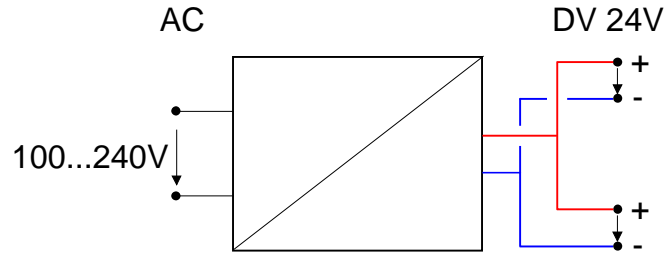

**Input
AC 100...240V**

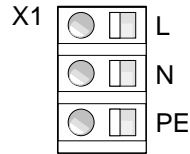

You have to provide the power supply with alternating voltage via the input slot.
A melting fuse protects the input against overload.

Line protection

To protect the main supply lines, you should install a miniature circuit-breaker of the following rating:

- Rated current at AC 230V: 6A
- Tripping characteristics: C

**Output
DC 24V, 2.5A**

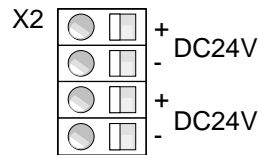

Here you may connect System 300 modules to two sockets, that need a external DC 24V voltage.
Both outputs are protected against short circuits and have each an output voltage of DC 24V at a total current of max. 2.5A.

LEDs

On the frontside of the power supply there are 3 LEDs for error diagnostics.
The following table shows the usage and the according colors.

Label	Color	Description
OH	red	Overheat: blinks when overheated
OL	yellow	Overload: blinks when the total electricity exceeds the allowed maximum total electricity of app. 4A.
OK	green	blinks when there is no error and the DC24V-voltage supply is present.

307-1BA00 - Technical data

PS 307 / 2.5A

Electrical Data	VIPA 307-1BA00
Dimensions and weight	
Dimensions WxHxD	40x125x120mm
Weight	250g
Input parameters	
Input voltage	AC 100...240V
- Rated value	
Mains frequency	50Hz or 60Hz
- Rated value	
- Permissible range	47Hz ... 63Hz
Rated input current	
- at 120V	0.58A
- at 230V	0.29A
inrush current (at 25°C)	30A
I ² t (at inrush current)	1A ² s
Output parameters	
Output voltage	DC 24V
- Rated value	
- Permissible range	24V±5%, open circuit-proof
- Ramp-up time	max. 1s
Output current	
- Rated value	2.5A, parallel wiring not supported, 4A (peak)
Short-circuit protection	electronic, overload; over temperature (IP 20)
Residual ripple	< 150mV _{pp} incl. spikes
Electrical parameters	
Temperature	
- Operation	0 ... 60°C (linear derating from 50°C on with 2.5%/°C)
- Storage	-25 ... +85°C
EMC	DIN IEC 61000-4-2 (ESD), -4 (Burst), -5 (Surge) DIN IEC 50081-2 (spurious emission) DIN IEC 61000-6-2 (interference irradiation)
Safety isolation	SELV circuit
Buffer time (at line voltage AC 230V)	min.10ms
Efficiency	typ. 90% at I _{nom}
Power consumption	max. 67W
Losses	6W at nominal load capacity
Diagnostics	
"Output voltage present" display	yes, LEDs

Power derating curve

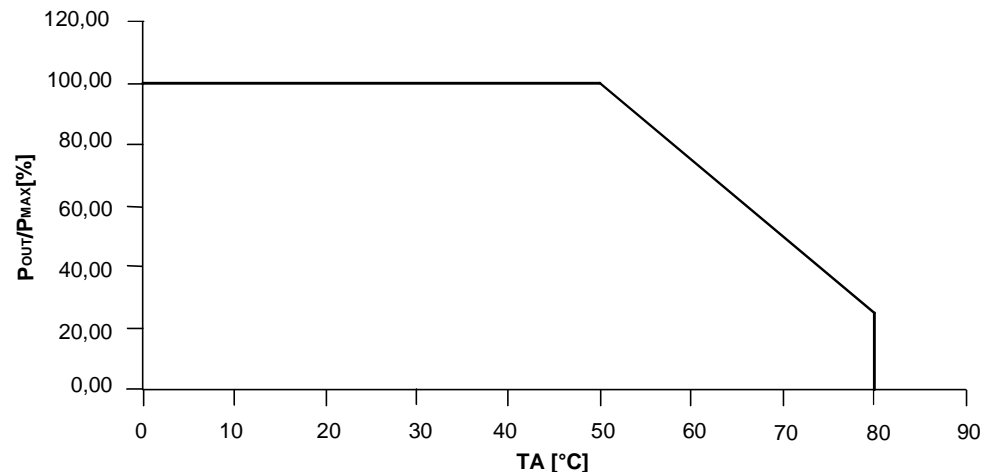

307-1EA00 - Deployment

Order data PS 307/5A VIPA 307-1EA00

Properties

- Output current 5A
- Output voltage DC 24V
- Connection to single-phase AC mains
AC 120/230V, 60/50Hz (switchable)
- Protection against short circuits, overloads and vacancy
- Useable together with System 300 on profile rail
- Safety isolation to EN 60950
- May be used as load power supply

Structure

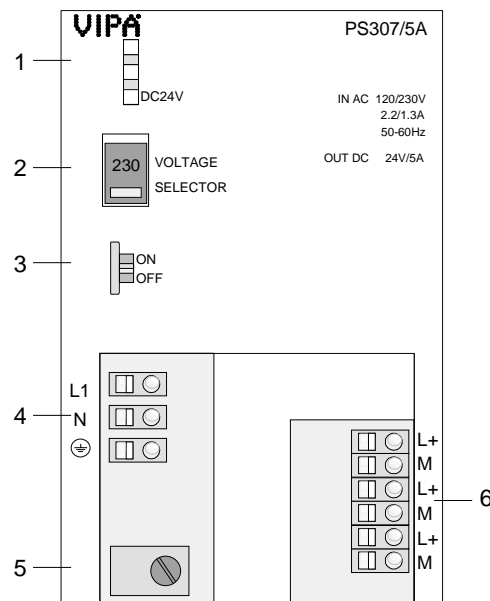

- [1] Status LED
 [2] Mains voltage selector switch AC 120/230V
 [3] ON/OFF switch

The following components are beneath a flap:

- [4] AC IN 120/230V
 [5] Strain relief
 [6] DC OUT 24V, 5A



Danger!

- Before installing or overhauling single components res. the whole system, the power supplies must be disconnected from voltage (pull the plug or remove the fuse)!
- Installation and modifications only by properly trained personnel!

Circuit diagram

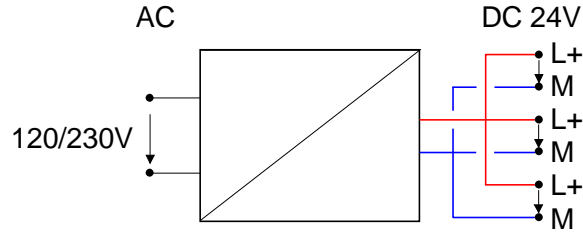

Input
AC 120/230V

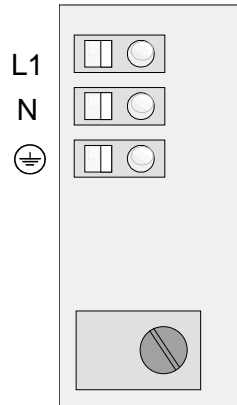

The power supply is provided with AC voltage by means of the input slot.

Please note before start-up that the input voltage corresponds to the adjusted value at the mains voltage selector switch!

The main supply cable should always be fixed by means of the strain relief!

Line protection

To protect the main supply lines, you should install a miniature circuit-breaker of the following rating:

- Rated current at AC 230V: 10A
- Tripping characteristics: C

Mains voltage selector switch

On delivery the power supply is adjusted to AC 230V input voltage. At the front side of the power supply there is a mains voltage selector switch to switch input voltage to AC 120V.

For this remove the transparent plastic cover by means of a screwdriver. Now you can select the requested input voltage with the screwdriver, too. Fix again the transparent plastic cover, now.

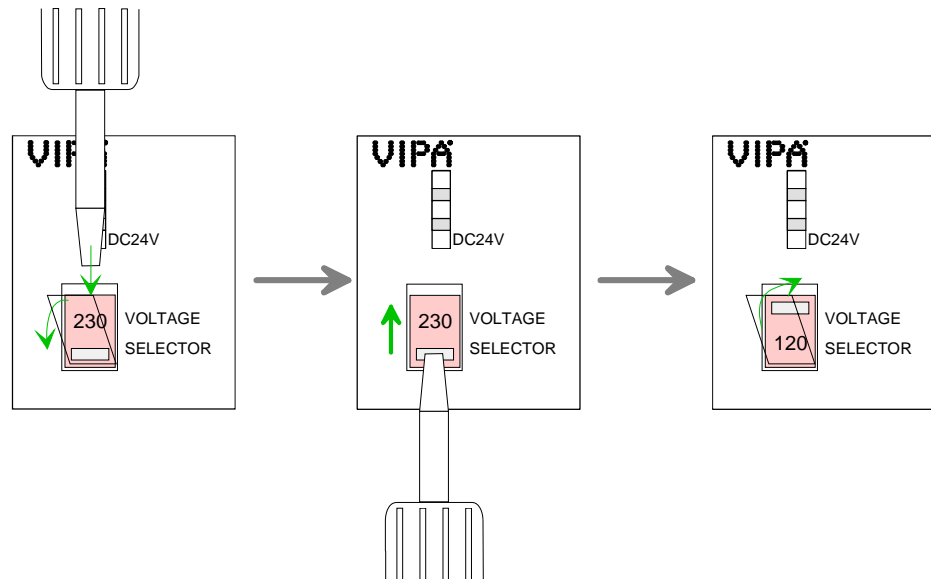

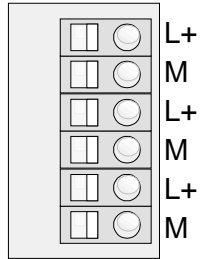
**Output
DC 24V, 5A**

Here DC 24V can be picked up via triple terminal. The outputs are protected against short circuit.

Please note that the sum current may not exceed maximally 5A.

LED

At the front side there is a LED labeled with "DC 24V" which serves the error diagnostics.

The following conditions can be indicated:

LED ...	Meaning
on	There is no error, DC 24V output voltage is present.
gets off	There is a short circuit at the secondary side or undervoltage on primary side or the power supply is damaged.
blinks	The sum of the individual currents exceeded the maximum total current of 5A.

**Danger!**

- Before installing or overhauling single components res. the whole system, the power supplies must be disconnected from voltage (pull the plug or remove the fuse)!
- Installation and modifications only by properly trained personnel!
- During operation the DC 24V LED is on. An error is indicated if the LED gets off or blinks.
- The usage out of the adjusted mains input voltage can damage the power supply.
- Durably exceeding the maximum total current the lifespan of the power supply is affected.

307-1EA00 - Technical data

PS 307 / 5A

Module name	307-1EA00
Dimensions and weight	
Dimensions WxHxD (mm)	80x125x120
Weight	740g
Input parameters	
Input voltage - Rated value	AC 120V/230V
Mains frequency - Rated value - Permissible range	50Hz or 60Hz 47Hz ... 63Hz
Rated input current - at 120V - at 230V	2.2A 1.3A
inrush current (at 25°C) I^2t (at inrush current)	45A 1.2A ² s
Output parameters	
Output voltage - Rated value - Permissible range - Ramp-up time	DC 24V 24V±5%, open circuit-proof max. 2.5s
Output current - Rated value	5A, parallel wiring not supported
Short-circuit protection	electronic non-latching 1.1 to 1.3 x I_N
Residual ripple	max. 150mV _{pp}
Electrical parameters	
Safety class to IEC 536 (DIN VDE 0106, Part 1)	I, with protective conductor
Isolation rating - Rated isolation voltage (24V to L1) - Tested voltage	AC 250V DC 2800V
Safety isolation	SELV circuit
Buffering of power supply failure (at 93V or 187V) - Repeat rate	min. 20ms min. 1s
Efficiency	87%
Power consumption	138W
Power loss	typ. 18W
Diagnostics	
"Output voltage present" display	yes, green LED

307-1KA00 - Deployment

Order data PS 307/10A VIPA 307-1KA00

Properties

- Output current 10A
- Output voltage DC 24V
- Connection to single-phase AC mains
AC 120/230V, 60/50Hz (switchable)
- Protection against short circuits, overloads and vacancy
- Useable together with System 300 on profile rail
- Safety isolation to EN 60950
- May be used as load power supply

Structure

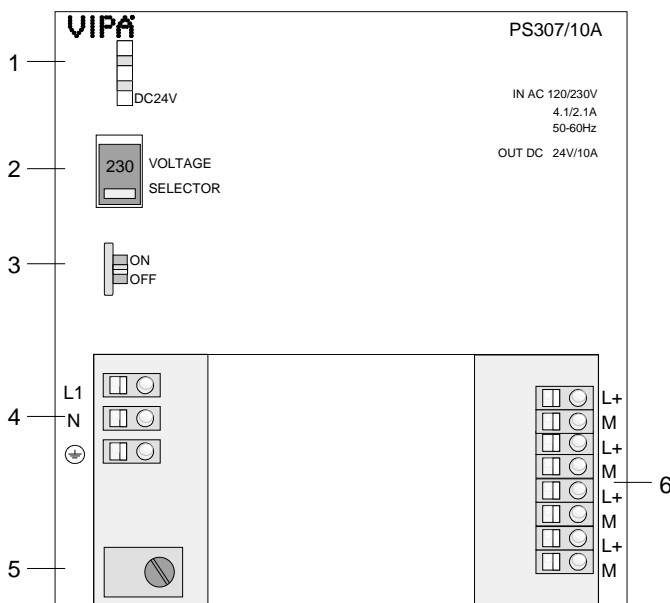

- [1] Status LED
- [2] Mains voltage selector switch AC 120/230V
- [3] ON/OFF switch

The following components are beneath a flap:

- [4] AC IN 120/230V
- [5] Strain relief
- [6] DC OUT 24V, 10A



Danger!

- Before installing or overhauling single components res. the whole system, the power supplies must be disconnected from voltage (pull the plug or remove the fuse)!
- Installation and modifications only by properly trained personnel!

Circuit diagram

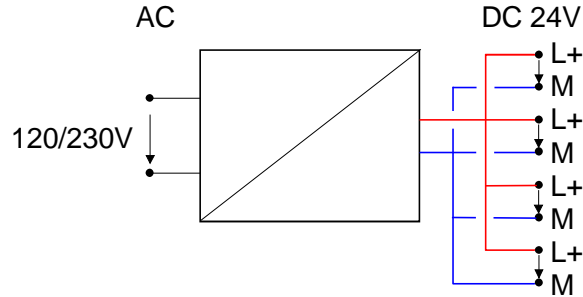

Input
AC 120/230V

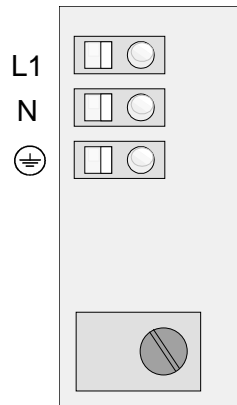

The power supply is provided with AC voltage by means of the input slot.

Please note before start-up that the input voltage corresponds to the adjusted value at the mains voltage selector switch!

The main supply cable should always be fixed by means of the strain relief!

Line protection

To protect the main supply lines, you should install a miniature circuit-breaker of the following rating:

- Rated current at AC 230V: 10A
- Tripping characteristics: C

Mains voltage selector switch

On delivery the power supply is adjusted to AC 230V input voltage. At the front side of the power supply there is a mains voltage selector switch to switch input voltage to AC 120V.

For this remove the transparent plastic cover by means of a screwdriver. Now you can select the requested input voltage with the screwdriver, too. Fix again the transparent plastic cover, now.

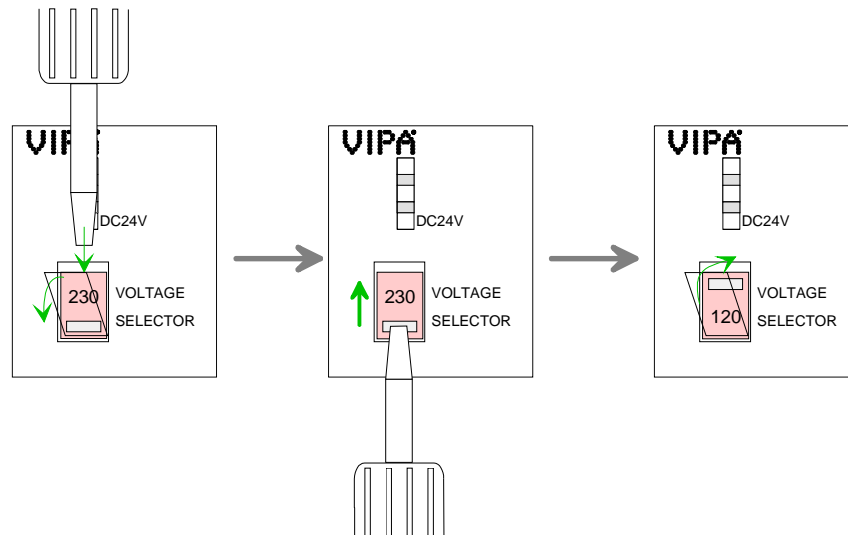

**Output
DC 24V, 10A**

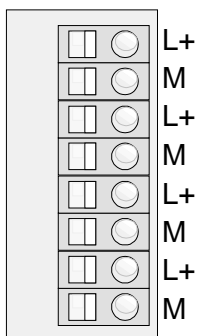

Here DC 24V can be picked up via quadruple terminal. The outputs are protected against short circuit.

Please note that the sum current may not exceed maximally 10A.

LED

At the front side there is a LED labeled with "DC 24V" which serves the error diagnostics

Auf der Front der Spannungsversorgung befindet sich eine mit "DC 24V " beschriftete grüne LED, die der Fehlerdiagnose dient.

The following conditions can be indicated:

LED ...	Meaning
on	There is no error, DC 24V output voltage is present.
gets off	There is a short circuit at the secondary side or undervoltage on primary side or the power supply is damaged.
blinks	The sum of the individual currents exceeded the maximum total current of 10A.



Danger!

- Before installing or overhauling single components res. the whole system, the power supplies must be disconnected from voltage (pull the plug or remove the fuse)!
- Installation and modifications only by properly trained personnel!
- During operation the DC 24V LED is on. An error is indicated if the LED gets of or blinks.
- The usage out of the adjusted mains input voltage can damage the power supply.
- Durably exceeding the maximum total current the lifespan of the power supply is affected.

307-1KA00 - Technical data

PS 307 / 10A

Module name	307-1KA00
Dimensions and weight	
Dimensions WxHxD (mm)	120x125x120
Weight	1100g
Input parameters	
Input voltage - Rated value	AC 120V/230V
Mains frequency - Rated value - Permissible range	50Hz or 60Hz 47Hz ... 63Hz
Rated input current - at 120V - at 230V	4.1A 2.1A
inrush current (at 25°C) I^2t (at inrush current)	55A 9A ² s
Output parameters	
Output voltage - Rated value - Permissible range - Ramp-up time	DC 24V 24V±5%, open circuit-proof max. 2.5s
Output current - Rated value	10A, parallel wiring not supported
Short-circuit protection	electronic non-latching 1.1 to 1.3 x I _N
Residual ripple	max. 150mV _{pp}
Electrical parameters	
Safety class to IEC 536 (DIN VDE 0106, Part 1)	I, with protective conductor
Isolation rating - Rated isolation voltage (24V to L1) - Tested voltage	AC 250V DC 2800V
Safety isolation	SELV circuit
Buffering of power supply failure (at 93V or 187V) - Repeat rate	min. 20ms min. 1s
Efficiency	87%
Power consumption	275W
Power loss	typ. 35W
Diagnostics	
"Output voltage present" display	yes, green LED

Appendix

A Index

3	
307-1BA00.....	3-4
Circuit diagram	3-5
Input.....	3-5
LEDs	3-5
Line protection	3-5
Output.....	3-5
Power derating.....	3-6
Properties	3-4
Structure	3-4
Technical data	3-6
307-1EA00.....	3-7
Circuit diagram	3-8
Input.....	3-8
LED.....	3-9
Line protection	3-8
Mains voltage selector switch... 3-8	
Output.....	3-9
Properties	3-7
Structure	3-7
Technical data	3-10
307-1KA00.....	3-11
Circuit diagram	3-12
Input.....	3-12
LED.....	3-13
Line protection	3-12
Mains voltage selector switch. 3-12	
Output.....	3-13
Properties	3-11
Structure	3-11
Technical data	3-14
<i>I</i>	
Installation possibilities	3-2
<i>P</i>	
PS 307 power supply.....	3-1
<i>S</i>	
Safety Information.....	3-2
System 300V	
Assembly.....	2-1, 2-5
Bus connector	2-2
Cabling	2-6
Front connectors.....	2-8
Central system	1-4
Components	1-4
Core cross-section	1-5
Decentral system.....	1-4
EMC	2-10
Basic rules	2-11
Environmental conditions	1-5
Installation dimensions	2-3
Installation guidelines	2-1, 2-10
Interference influences.....	2-10
Introduction.....	1-1
Isolation of conductors	2-12
Overview.....	1-3
Peripheral modules	1-4
Safety Information	1-2
Structure.....	2-4
System overview.....	3-3

